

SPK 61502

KNUCKLE BOOM CRANE

IDEAL LIFTING SOLUTION FOR 4 AXLE TRUCKS



TECHINICAL SPECIFICATION

Product Description

- Equipped with load holding valves for safe crane operations
- High speed boom extension and retraction with return oil utilization
- Optimized lifting performance with the use of high tensile steel and hexagonal boom design
- Lightweight yet robust construction according to European Standards (EN 12999)
- Professional installation solutions and technical supports
- Standard package includes
 - Overload protection system (Paltronic 50)
 - Emergency stop button
 - High power lifting system (HPLS)
 - Radio remote control (Only EH)
 - Oil tank loose
 - Load holding valves
 - Painting
 - High pressure filter
 - Digital hour counter
 - Load hook
 - Crane preservation
 - Mounting bolts
 - Spare parts catalogue
 - Crating

Technical Data

Basic Data	SPK 61502
Max. lifting moment [mt]	57.3
Max. lifting capacity [kg]	21500
Max. hydraulic outreach [m]	15.9
Max. hydraulic outreach lifting capacity [kg]	3000
Max. number of extension boom	6 (E)
Slewing angle [°]	370
Slewing moment [mt]	6.5
Max. stabilizer spread [mm]	7400
Std. stabilizer spread [mm]	7400
Fitting space required [mm]	1560
Width folded [mm]	2550
Max. operating pressure [bar]	350
Recommended pump capacity [l/min]	80 - 100
Dead weight standard crane [kg]	5358

LIFTING CHART

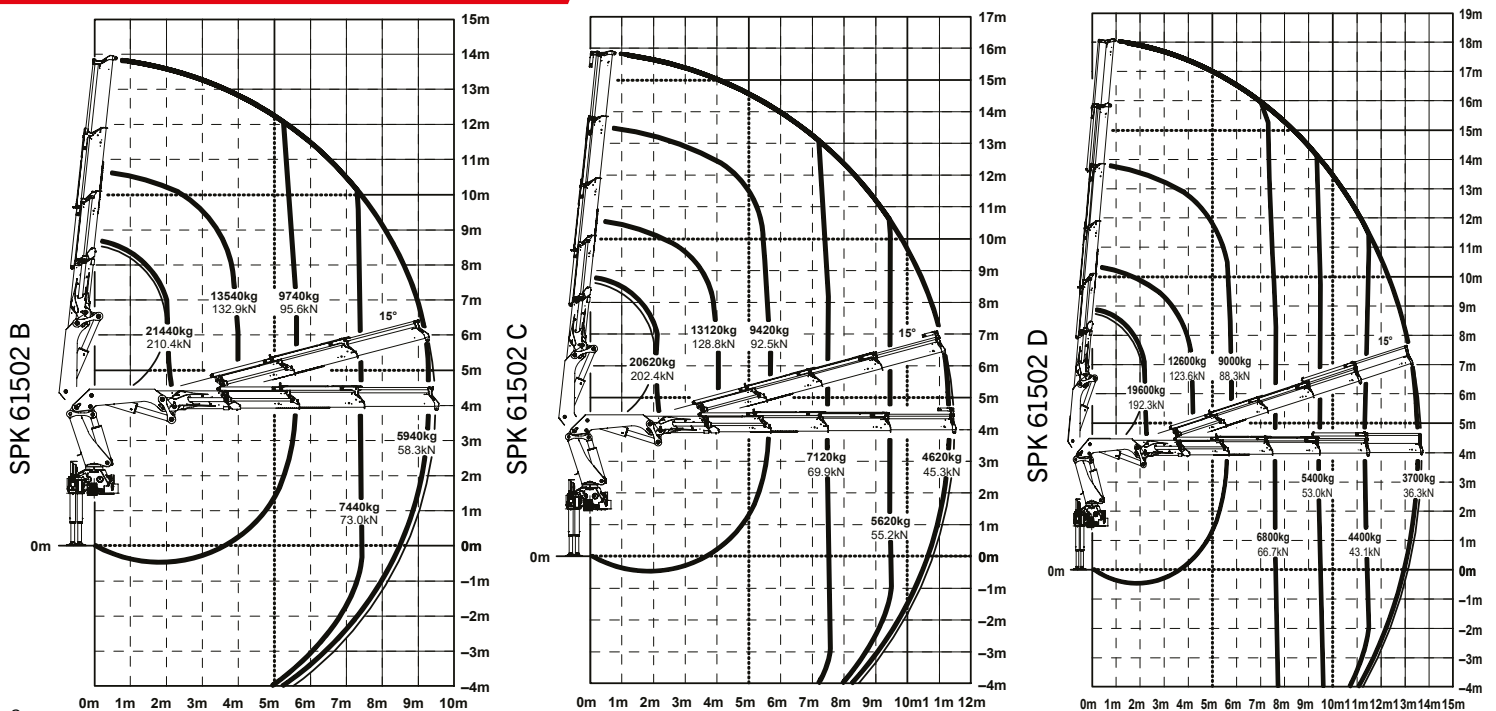

CRANE DIMENSION

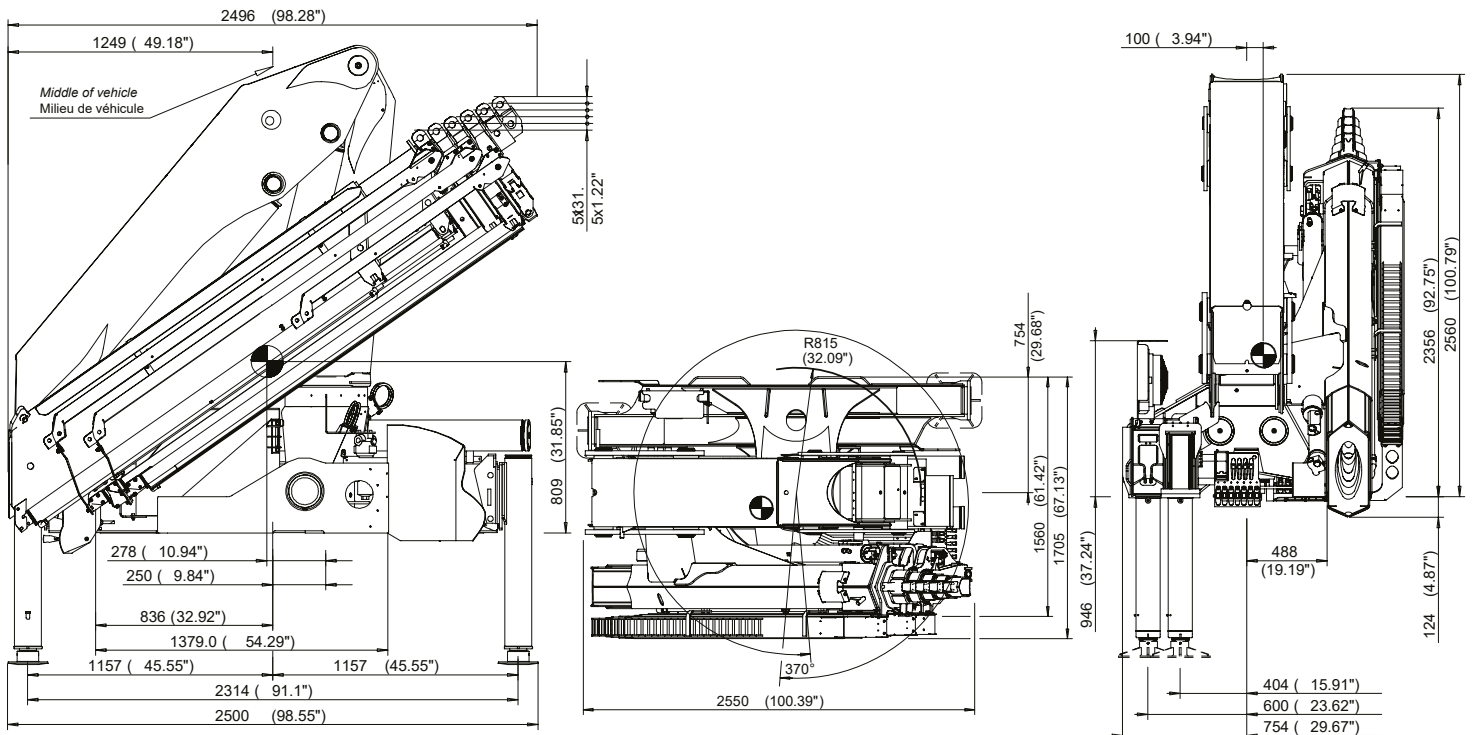

Subject to change, production tolerances have to be taken into account.

FEATURES AND OPTIONS



Ergonomic Crane Control

- Ergonomically arranged operating levers for all crane functions
- Functional design for better comfort during crane operation
- Straightforward service and maintenance



High Density Paint

- Top quality surface paint with corrosion protection
- Long term UV-resistant coating
- Aesthetically pleasing and attractive colour



Load Holding Valve

- Holds the cylinder in position
- Standard fittings on all cylinder
- Strategic positioned to protect from damage



High speed extension

- Increase extension and retraction speed of the boom system
- Crane works faster with return oil utilization
- Time saving during crane operation



Radio Remote Control

- Efficient control of the crane remotely
- Safe crane operation outside of the danger zone
- Easy maintenance and quick troubleshooting



Top Seat

- Excellent visibility of the surrounding area
- Foldable sun protection umbrella for hot weather
- Seat cover to prevent exposure from sun



Hydraulic Overload Safety Device

- Prevents the crane from overloading
- Overload protection system with emergency cut-off function
- Stops all movements of the crane that increases load



Hose Equipment for Attachments

- Additional hydraulic functions for attachments
- Simple installation with hose tray protection
- Diverse applications suitable for different industry

PALFINGER ASIA PACIFIC PTE LTD
3 International Business Park
Nordic European Center | #05-25/26
609927 | Singapore
T: +65 6591 9191
asia@palfinger.com

Cranes shown in the leaflet are partially optional equipped and do not always correspond to the standard version. Country-specific regulations must be observed. Dimensions may vary. Subject to technical changes, errors and translation mistakes.