

# SPK 12000

# KNUCKLE BOOM CRANE

IDEAL LIFTING SOLUTION FOR 2 AXLE TRUCKS



# TECHNICAL SPECIFICATION

## Product Description

- Equipped with load holding valves for safe crane operations
- High speed boom extension and retraction with return oil utilization
- Optimized lifting performance with the use of high tensile steel and hexagonal boom design
- Lightweight yet robust construction according to European Standards (EN 12999)
- Professional installation solutions and technical supports
- Standard package includes
  - Oil tank mounted
  - Load holding valves
  - Painting
  - High pressure filter
  - Digital hour counter
  - Load hook
  - Crane preservation
  - Mounting bolts
  - Spare parts catalogue
  - Crating

## Technical Data

Basic Data	SPK 12000
Max. lifting moment [mt]	11.6
Max. lifting capacity [kg]	6790
Max. hydraulic outreach [m]	14.6
Max. hydraulic outreach lifting capacity [kg]	530
Max. number of extension boom	5 (D)
Slewing angle [°]	420
Slewing moment [mt]	1.4
Max. stabilizer spread [mm]	5600
Std. stabilizer spread [mm]	5600
Fitting space required [mm]	775
Width folded [mm]	2489
Max. operating pressure [bar]	300
Recommended pump capacity [l/min]	35 - 50
Dead weight standard crane [kg]	1380

## LIFTING CHART

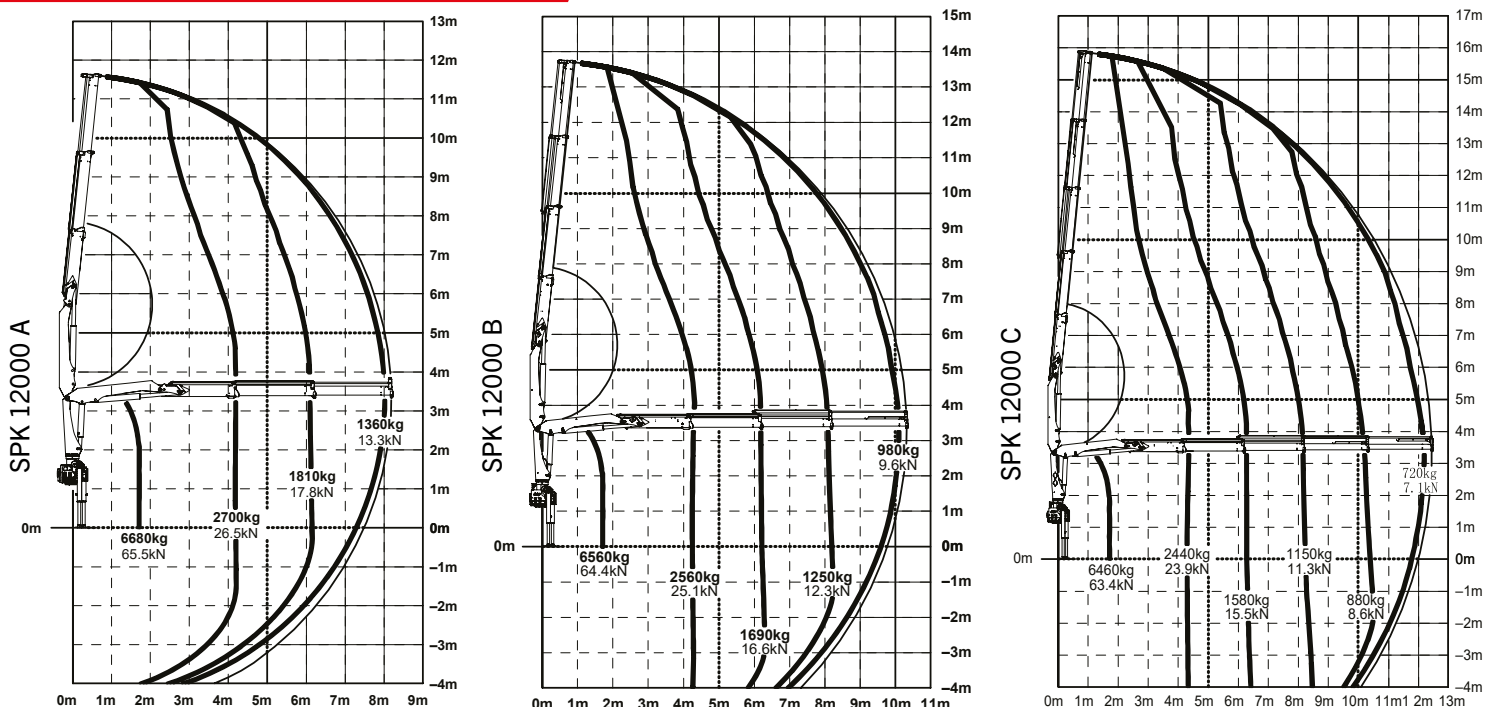

## CRANE DIMENSION

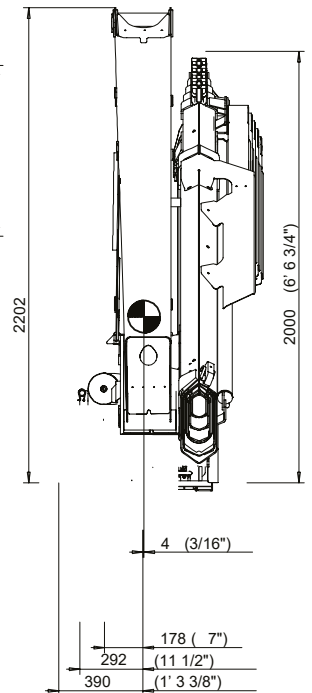
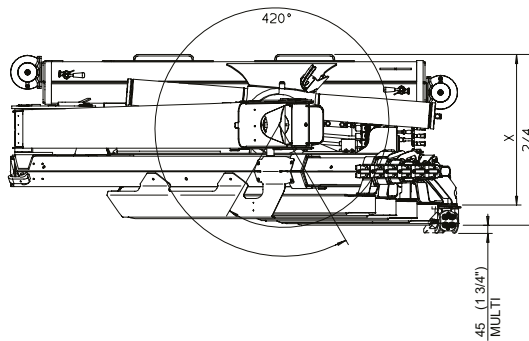
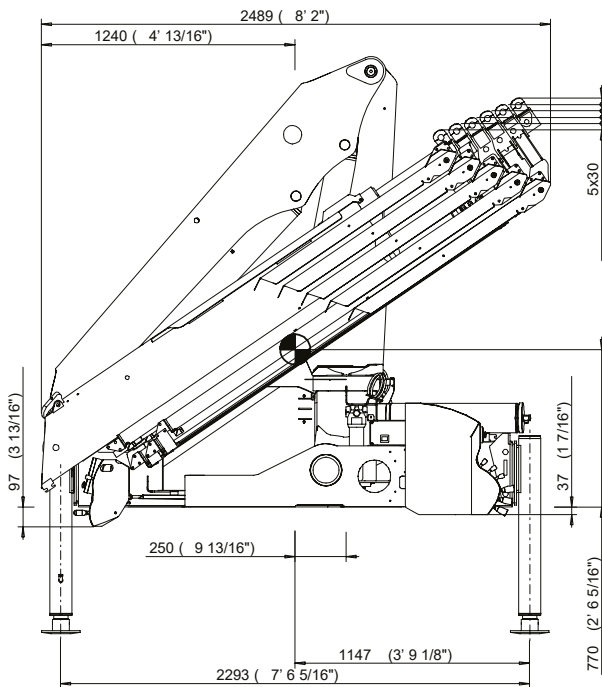

hydraulic extensions extensions hydrauliques	X
<b>1</b>	775 mm 2' 6 1/2"
<b>2(A)</b>	791 mm 2' 7 1/8"
<b>3(B)</b>	806 mm 2' 7 3/4"
<b>4(C)</b>	932 mm 3' 11/16"

Subject to change, production tolerances have to be taken into account.

## FEATURES AND OPTIONS



### Ergonomic Crane Control

- Ergonomically arranged operating levers for all crane functions
- Functional design for better comfort during crane operation
- Straightforward service and maintenance



### High Density Paint

- Top quality surface paint with corrosion protection
- Long term UV-resistant coating
- Aesthetically pleasing and attractive colour



### Load Holding Valve

- Holds the cylinder in position
- Standard fittings on all cylinder
- Strategic positioned to protect from damage



### High speed extension

- Increase extension and retraction speed of the boom system
- Crane works faster with return oil utilization
- Time saving during crane operation



### Radio Remote Control

- Efficient control of the crane remotely
- Safe crane operation outside of the danger zone
- Easy maintenance and quick troubleshooting



### Top Seat

- Excellent visibility of the surrounding area
- Foldable sun protection umbrella for hot weather
- Seat cover to prevent exposure from sun



### Hydraulic Overload Safety Device

- Prevents the crane from overloading
- Overload protection system with emergency cut-off function
- Stops all movements of the crane that increases load



### Hose Equipment for Attachments

- Additional hydraulic functions for attachments
- Simple installation with hose tray protection
- Diverse applications suitable for different industry

PALFINGER ASIA PACIFIC PTE LTD  
3 International Business Park  
Nordic European Center | #05-25/26  
609927 | Singapore  
T: +65 6591 9191  
[asia@palfinger.com](mailto:asia@palfinger.com)

Cranes shown in the leaflet are partially optional equipped and do not always correspond to the standard version. Country-specific regulations must be observed. Dimensions may vary. Subject to technical changes, errors and translation mistakes.