

# SRC250C

SRC250C ROUGH-TERRAIN CRANE  
25 TONS LIFTING CAPACITY

Quality Changes the World

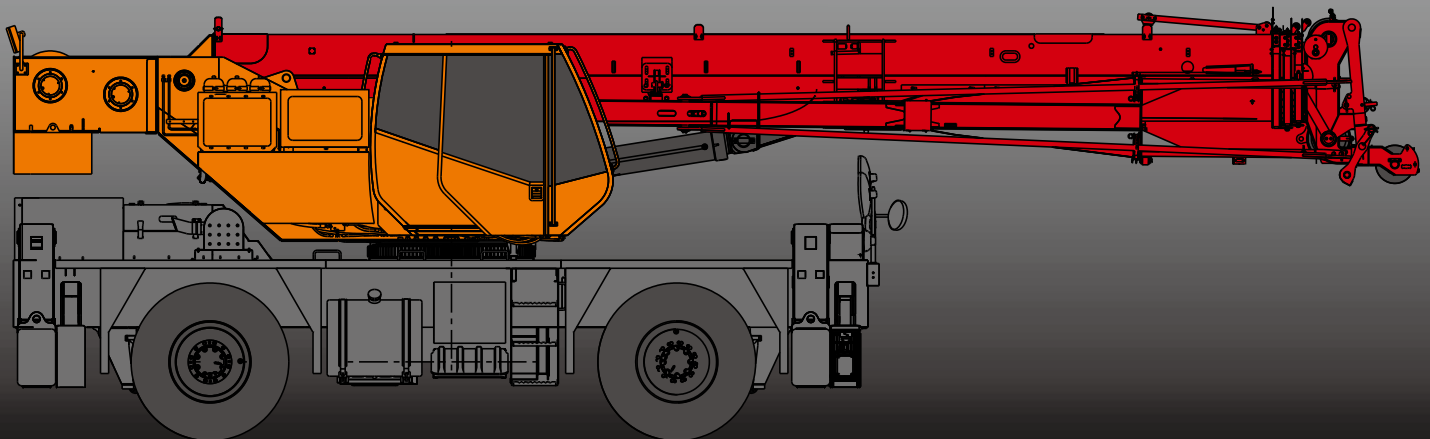

**SANY**

■ SANY Automobile Hoisting Machinery is one of the core business unit of Sany Heavy Industry, mainly engaged in the research and development of high end, mid to large tonnage crane series, including mobile crane, crawler crane, tower crane and loader crane. It has two industrial parks in Ningxiang and Huzhou, since entering the market, the products of Sany Automobile Hoisting Machinery have received worldwide recognition with advanced technology, lean manufacturing, high reliability and excellent service.



# SANY ROUGH-TERRAIN CRANE

## CONTENT

- 04 Icon
- 05 Selling points
- 06 Introduction
- 09 Dimension
- 10 Technical Parameter
- 11 Operation Condition
- 12 Load Chart
- 17 Wheel Crane Family Map

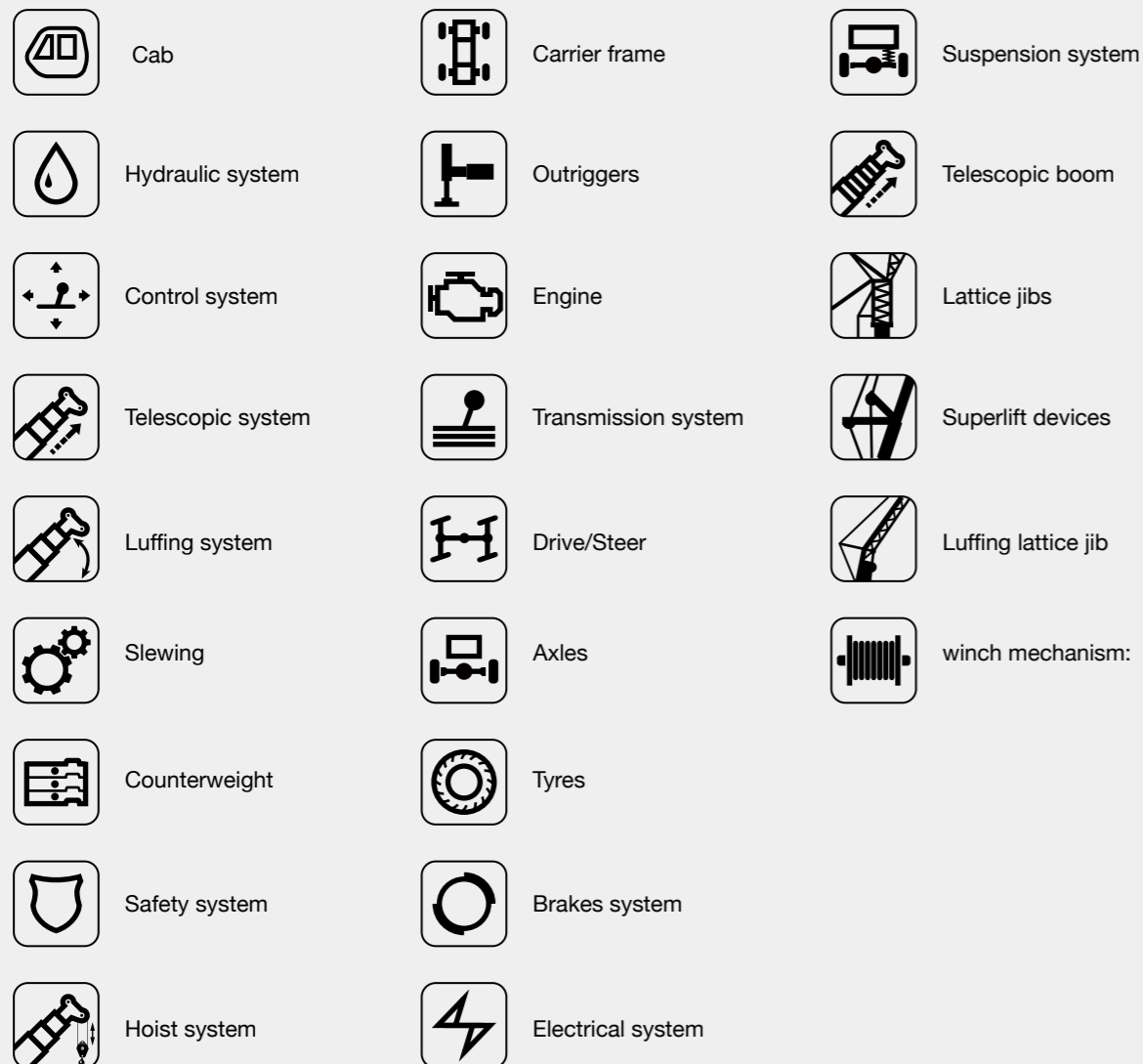

### Excellent traveling capacity and high-performance chassis system

Four-wheel drive is applied with full hydraulic power steering system, and with four steering modes to provide good mobility. Trafficability and comfortableness of the complex road condition is improved thanks to its Min. turning radius of less than 5.5m.

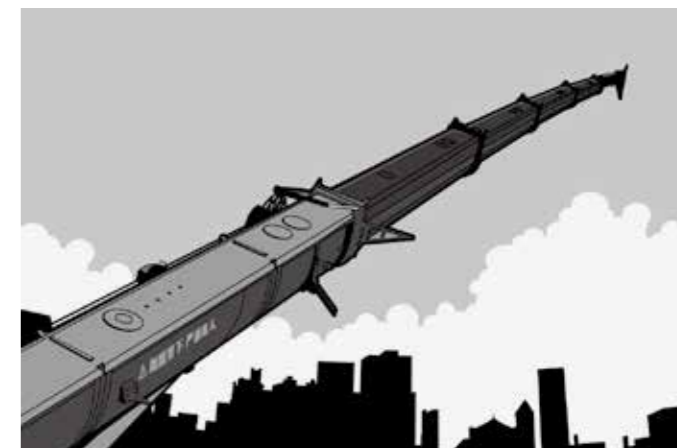

### Ultra long and super strong boom system

Four-section boom with high strength steel structure and optimized U-shaped section, reducing weight and improving safety significantly. Jib mounting angles are 0°, 15°, and 30° which ensure fast and convenient change-over between different operating conditions so as to improve working efficiency of the machine.



### Highly effective and original hydraulic system

Hydraulic system load feedback and constant power control is applied to provide strong lifting capacity and good micro-mobility. Unique steering buffer design guarantees smooth braking operation.



### Safe and reliable control system

Self-developed controller SYMC specially for engineering machinery is configured. The application of CAN-bus fully digital network control technology ensures stable control signal, simple harness and high reliability. It can feedback the data information and monitor the working condition of whole crane in real-time. Load moment limiter configuring with comprehensive intelligent protection system is adopted with precision within 0-10%. The adoption of comprehensive logic and interlock control system ensures more safe and reliable operation.

## Introduction



## Cab

- The self-made cab adopts ergonomic design with sliding door, safety glass, anti-corrosion steel, soft interior decoration, large interior space, panoramic sunroof and adjustable seats, air conditioner and electric window wiper etc. to provide easier and more comfortable operation. Meticulously designed industrial style and novel appearance are applied for cab. Load moment limiter display is configured to achieve the combination of main console and operating display system, making all operating condition data of lighting operation clear at a glance.



## Hydraulic system

- High-quality key hydraulic components such as main oil pump, rotary pump, main valve, winch motor, and balancing parts etc. are adopted to achieve stable and reliable operation of the hydraulic system. Superior operation performance is guaranteed by accurate parameter matching.
- Through the adoption of load sensitive variable displacement piston pump, pump displacement can be adjusted in real-time, achieving high-precision flow control, with no energy loss during operation;
- Main valve has flow compensation and load feedback control function. It significantly enhances control stability for single action and combined action under different operation conditions.
- Winch adopts electronically controlled variable motor, to ensure high operation efficiency. Max. single line speeds of main and auxiliary winches is up to 125m/min;
- Slewing system is equipped with the integrated slewing buffer valve, with free slipping function, to ensure more stable starting and control of the slewing operation and excellent micro-mobility.
- Hydraulic oil tank capacity: 570L.



## Control system

- CAN-bus instrument: CAN-bus instrument with a combined intelligent control electrical system is used for easy reading of the traveling parameters at any time. Engine fault warning function enables convenient and fast maintenance.
- With full security protection system, main and auxiliary winches are equipped with over-rolling out limiter and height limiters to prevent over-rolling out and over-hoisting of steel rope, including tip-over and limit angle protection.
- Load moment limiter: The adoption of highly intelligent load moment limiter system can comprehensively protect lifting operation, ensuring accurate, stable and comfort operation.
- The fault diagnosis system can detect superstructure electricity, hydraulic action, chassis (for major safety failure), engine and gearbox for fault to ensure reliable operation of the crane.



## Telescopic system

- Four-section boom is applied with basic boom length of 9.9m, full-extended boom length of 31.5m, jib length of 12.5m and lifting height of fully extended boom length of 32.5m respectively. Max. lifting height is 45m including jib. It is made of fine grain high-strength steel, with U-shaped cross section and with telescopic operation controlled independent by double cylinder rope.



## Luffing system

- Dead-weight luffing provides more stable luffing operation at low energy loss. Dual-action single piston hydraulic pressure cylinder with safety valve is adopted.
- Luffing angle range is  $-3^{\circ} \sim 80^{\circ}$ .

## Introduction



## Slewing system

- 360° rotation can be achieved, with Max. slewing speed of 2.5r/min. Hydraulic controlled proportional speed adjustment is applied, providing stable and reliable operation of the system. Unique slewing buffer design ensures more stable braking operation.



## Counterweight

- The total weight of fixed counterweight is 1000kg, no flexible counterweight.



## Safety system

- Load moment limiter: Load moment limiter calculation system based on lifting load mechanical model is established using an analytical mechanics method, with rated lifting accuracy up to 0-10% through on-line non-load calibration, providing full protection to lifting operation. In case of overload operation, system will automatically issue an alarm to provide safety protection for manipulation.
- Balance valve, overflow valve, and two-way hydraulic lock etc. components are configured for hydraulic system, thus achieving stable and reliable operation of the hydraulic system.
- Main and auxiliary winches are equipped with over roll-out limiter, to prevent over rolling-out of wire rope.
- Boom and jib ends are equipped with height limiters respectively to prevent over-hoisting of wire rope.
- Boom head is equipped with anemometer, press sensor, to indicate the working condition of whole crane in real-time, giving an alarm and cut off the dangerous action automatically.



## Hoist system

- The adoption of pump and motor double variable speed control ensures high efficiency and excellent energy saving functionality. With perfect combination of winch balance valve and unique anti-slip technology, heavy load can lift and lower smoothly. Closed winch brake and winch balance valve effectively prevent imbalance of the hook. High strength, anti-swirl steel wire is equipped for high-precision hoisting positioning.
- Equipped with one 320kg main hook and one 85kg auxiliary hook, and Main and auxiliary hook steel rope diameters are 16mm, the rope length is 175m and 105m respectively.



## Carrier frame

- Carrier frame is of box-type structure that is welded with high-strength steel plate, featuring high lifting capacity.

## Introduction

- Outriggers**
- H-type outrigger structure and 4-point support is adopted, with Max. span up to 6.7m×6.5m. Featuring easy operation and high stability. Fine grain high strength steel material is adopted and dual-direction hydraulic lock is used for the protection of vertical span cylinder.
- Engine**
- Type: Inline six-cylinder, water cooled, supercharged and inter-cooling diesel engine
  - Rated power: 154kw/2200r/min
  - Environment-protection: Emission complies with Statelll standard
  - Capacity of fuel tank: 300L
- Transmission system**
- Transmission case: Manual/Automatic transmission case. There are six gears in gearbox. The speed ratio range is large which meets the requirements of low gradeability speed and high traveling speed.
  - Transmission shaft: With optimized arrangement of the transmission shaft, the transmission is stable and reliable.
- Drive/Steer**
- 4×4 drive way is adopted, full hydraulic power steering is applied, having front wheel steering, rear wheel steering, four-wheel steering and crab traveling modes.
- Axles**
- Front and rear axles are all slewing drive axles.
- Tyres**
- 4\*—14.00R25
- Brakes system**
- Double-circuit braking system is adopted, if one circuit fails, the other circuit can ensure normal operation, thus improving the safety and reliability of brake system.
  - Traveling brake: all wheels use the unique slewing brakes and dual-circuit brake system and are equipped with drum brakes.
  - Parking brake is drum brakes equipped on the front axle export flange.
- Electrical system**
- With 2\*12V maintenance-free battery and mechanical power main switch, power of the whole machine can be cut off manually.

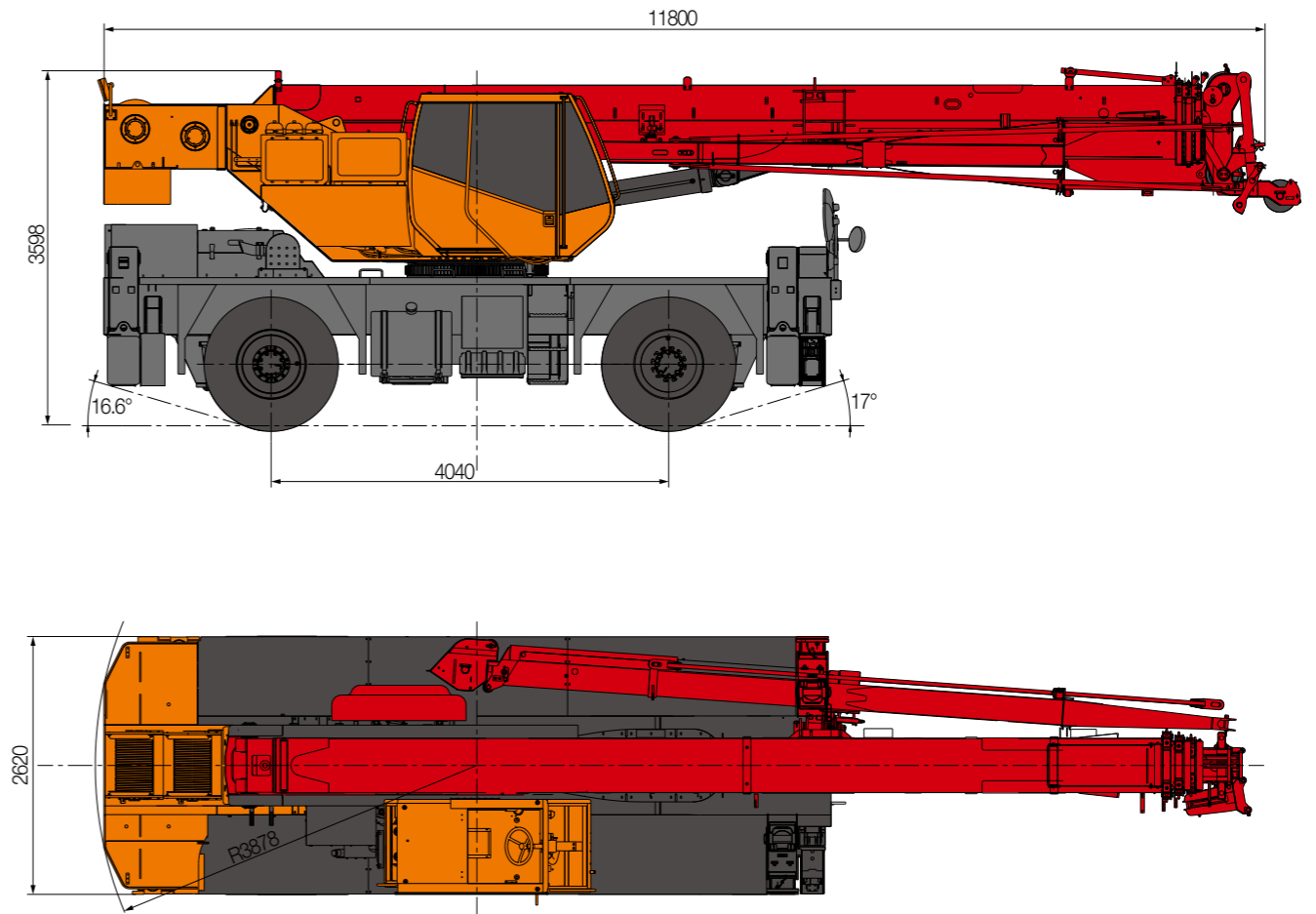

Type	Item	Parameter		
Capacity	Max. lifting capacity	25 t		
Dimensions	Overall length	12155 mm		
	Overall width	2620 mm		
	Overall height	3600 mm		
	Axle distance	4040 mm		
Weight	Overall weight	27945 kg		
	Axle load	Front axle load	14000 kg	
		Rear axle load	13945 kg	
Engine	Rated power	154 kW/ 2200 rpm		
	Rated torque	800 N.m/ 1400 rpm		
Traveling	Max.traveling speed	40 km/h		
	Turning radius	Min.turning radius	8.5 /5.5 m	
	Wheel formula		4×4	
	Min.ground clearance		350 mm	
	Approach angle		17 °	
	Departure angle		16 °	
	Max.gradeability		55%	
Main Performance Data	Temperature range		- 20 ° ~ + 46 °	
	Min.rated range		3 m	
	Tail slewing radius of swingtable		3.841 m	
	Boom section		4	
	Boom shape		U-shaped	
	Max.lifting moment	Base boom		968kN·m
		Full-extend boom		605kN·m
		Full-extend boom+jib		243 kN·m
	Boom length	Base boom		9.9 m
		Full-extend boom		31.5 m
		Full-extend boom+jib		44 m
Outrigger span (Longitudinal×Transversal)		6.7 × 6.5 m		
Jib offset		5 ° , 24 ° , 45 °		
Working speed	Max.single rope lifting speed of main winch (no load)		125 m/min	
	Max.single rope lifting speed of auxiliary winch (no load)		125 m/min	
	Full extension/retraction time of boom		65 / 40 s	
	Full lifting/descending time of boom		45 / 50 s	
	Slewing speed		2.5 r/min	
Air condition	Superstructure		Cooling	

## SRC250C Working Ranges

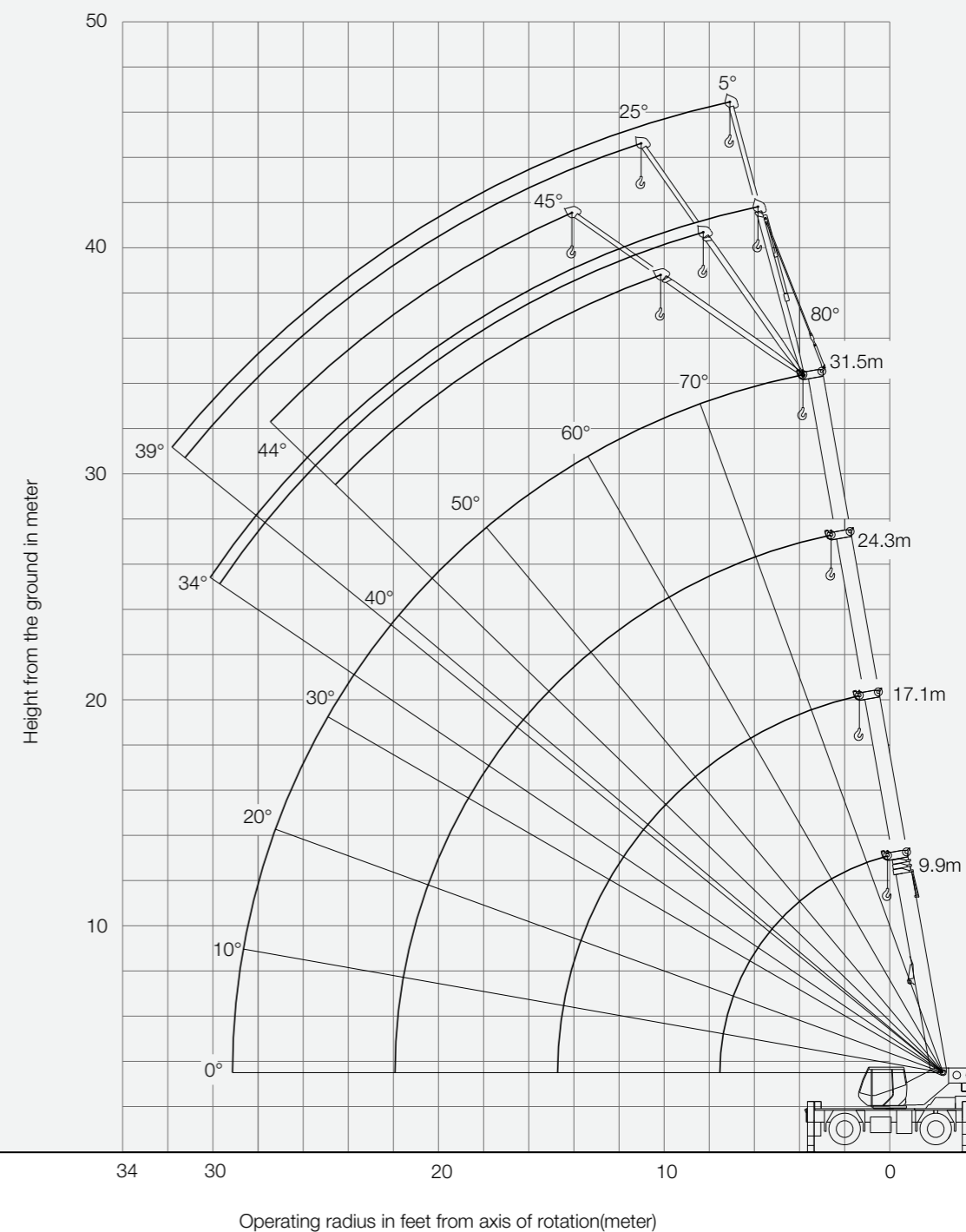

**Prerequisites:**  
 ① Boom operating conditions:9.9m-31.5m  
 ② The span of outriggers is 6.7m×6.5m  
 ③ 360°rotation is applied  
 ④ Counterweight is 1T

Working range (m)	Main Boom(m)				Working range (m)
	9.9	17.1	24.3	31.5	
3	25.00				3
3.5	25.00	19.00			3.5
4	23.00	19.00			4
4.5	21.20	18.00			4.5
5	19.40	16.70	12.50		5
5.5	17.80	15.60	11.75		5.5
6	16.30	14.60	11.10		6
6.5	15.20	13.80	10.50	7.00	6.5
7	13.70	13.00	10.00	7.00	7
8		11.00	9.00	7.00	8
9		8.90	8.20	6.30	9
10		7.40	7.60	5.80	10
11		6.10	6.70	5.30	11
12		5.20	5.70	5.15	12
13		4.40	5.00	4.70	13
14		3.70	4.30	4.30	14
15			3.70	4.00	15
16			3.30	3.60	16
17			2.90	3.20	17
18			2.50	2.80	18
19			2.20	2.50	19
20			2.00	2.30	20
21			1.80	2.00	21
22				1.80	22
24				1.45	24
26				1.20	26
28				1.00	28
Min angle (°)	0.00	0.00	0.00	0.00	Min angle (°)
Parts of line	8	6	4	3	Parts of line

**Prerequisites:**  
 ① Boom operating conditions:9.9m-31.5m  
 ② The span of outriggers is 6.7m×5m  
 ③ 360°rotation is applied  
 ④ Counterweight is 1T

Working range (m)	Main Boom(m)				Working range (m)
	9.9	17.1	24.3	31.5	
3	25.00				3
3.5	25.00	19.00			3.5
4	23.00	19.00			4
4.5	21.20	18.00			4.5
5	18.60	16.70	12.50		5
5.5	15.50	15.20	11.75		5.5
6	12.90	12.70	11.10		6
6.5	10.80	10.90	10.50	7.00	6.5
7	9.30	9.50	10.00	7.00	7
8		7.40	8.20	7.00	8
9		5.90	6.60	6.30	9
10		4.80	5.50	5.60	10
11		4.00	4.60	4.80	11
12		3.30	3.90	4.10	12
13		2.70	3.30	3.50	13
14			2.85	3.00	14
15			2.40	2.60	15
16			2.00	2.20	16
17			1.70	1.90	17
18			1.50	1.60	18
19			1.30	1.40	19
20				1.20	20
Min angle (°)	0.00	0.00	25.00	43.00	Min angle (°)

## Prerequisites:

- ① Boom operating conditions:9.9m-31.5m
- ② The span of outriggers is 6.7m×3.6m
- ③ 360°rotation is applied
- ④ Counterweight is 1T

Working range (m)	Main Boom(m)				Working range (m)
	9.9	17.1	24.3	31.5	
3	25.00				3
3.5	20.00	19.00			3.5
4	14.70	15.70			4
4.5	11.40	12.60			4.5
5	9.10	10.20	10.70		5
5.5	7.50	8.50	8.90		5.5
6	6.20	7.20	7.60		6
6.5	5.20	6.20	6.50	6.70	6.5
7	4.40	5.30	5.70	5.80	7
8		4.10	4.40	4.60	8
9		3.20	3.50	3.60	9
10		2.50	2.80	2.90	10
11		1.90	2.20	2.40	11
12		1.50	1.80	1.90	12
13		1.10	1.40	1.50	13
14			1.10	1.20	14
15				1.00	15
Min angle (°)	0	20	42	55	Min angle (°)

## Prerequisites:

- ① Boom operating conditions(fully extended boom length+jib length), max.length is 31.5m+7.7/12.5m
- ② The span of outriggers is 6.7m×6.5m
- ③ 360°rotation is applied
- ④ Counterweight is 1T

Working angle (°)	7.7			12.5			Working angle (°)
	5	25	45	5	25	45	
80	3000	2100	1600	2000	1200	800	80
76	3000	2100	1600	2000	1200	800	76
72	3000	2100	1600	1750	1100	800	72
70	2800	2100	1600	1650	1050	800	70
65	2350	1800	1500	1400	950	780	65
60	2000	1550	1350	1200	900	750	60
55	1450	1350	1200	1050	850	740	55
50	1050	1000	950	850	750	700	50
45	750	700	650	600	550	500	45
40	550	500		400	400		40
35	350	320					35
Min. angle(°)	34.00	34.00	44.00	39.00	39.00	44.00	Min. angle(°)

- Prerequisites:**
- ① Boom operating conditions:9.9-24.3m
  - ② With tyre static lifting load
  - ③ Front and 360°rotation is applied
  - ④ Counterweight is 1T

Radius (m)	9.9		17.1		24.3	Radius (m)
	FRONT	360°	FRONT	360°	FRONT	
3.5	12.5	5.8				3.5
4	11	4.3	7.5	5.2		4
4.5	9.8	3.2	7.5	4.1	6	4.5
5	8.5	2.4	6.8	3.2	5.8	5
5.5	7	1.8	6	2.6	5.3	5.5
6	5.8	1.3	5.4	2.1	4.8	6
6.5	5		4.8	1.6	4.4	6.5
7			4.2	1.3	4	7
8			3.3		3.4	8
9			2.6		2.9	9
10			2.1		2.5	10
11			1.7		2.1	11
12			1.4		1.8	12
13					1.5	13
14					1.25	14

- Prerequisites:**
- ① Boom operating conditions:9.9-24.3m
  - ② Creep (traveling with load),1.6km/h
  - ③ Front side only
  - ④ Counterweight is 1T

Radius (m)	9.9	17.1	24.3	Radius (m)
	FRONT	FRONT	FRONT	
3.5	8			3.5
4	7.2	6		4
4.5	6.6	6	4.4	4.5
5	6	5.6	4.4	5
5.5	5.4	4.9	4.1	5.5
6	4.6	4.4	3.8	6
6.5	4	3.9	3.5	6.5
7		3.5	3.3	7
8		2.7	2.8	8
9		2.1	2.3	9
10		1.7	1.9	10
11		1.3	1.6	11
12		1	1.3	12
13			1.1	13
14				14
15				15

■ TRUCK CRANE

- STC200**: Maximum Load Capacity: 20t, Telescopic Boom: 4 Sections, 10.6-33m
- STC250**: Maximum Load Capacity: 25t, Telescopic Boom: 4 Sections, 10.65-33.5m
- STC250H**: Maximum Load Capacity: 25t, Telescopic Boom: 5 Sections, 10.5-39.5m
- STC300S**: Maximum Load Capacity: 30t, Telescopic Boom: 5 Sections, 10.6-40.5m
- STC300TH**: Maximum Load Capacity: 30t, Telescopic Boom: 4 Sections, 10.6-33.5m
- STC300H**: Maximum Load Capacity: 30t, Telescopic Boom: 5 Sections, 10.5-39.5m
- STC500**: Maximum Load Capacity: 50t, Telescopic Boom: 5 Sections, 11.5-43m
- STC550**: Maximum Load Capacity: 55t, Telescopic Boom: 5 Sections, 11.5-43m
- STC600S**: Maximum Load Capacity: 60t, Telescopic Boom: 5 Sections, 11.3-43.5m
- STC750**: Maximum Load Capacity: 75t, Telescopic Boom: 5 Sections, 11.8-45m
- STC800S**: Maximum Load Capacity: 80t, Telescopic Boom: 5 Sections, 12.2-47m
- STC1000**: Maximum Load Capacity: 100t, Telescopic Boom: 5 Sections, 13.5-52m
- STC1000C**: Maximum Load Capacity: 100t, Telescopic Boom: 6 Sections, 13.25-60m
- STC1000S**: Maximum Load Capacity: 100t, Telescopic Boom: 5 Sections, 12.2-56m
- STC1200S**: Maximum Load Capacity: 120t, Telescopic Boom: 7 Sections, 12.6-63.5m
- STC1300C**: Maximum Load Capacity: 130t, Telescopic Boom: 6 Sections, 13.3-69m
- STC1600**: Maximum Load Capacity: 160t, Telescopic Boom: 6 Sections, 13.4-69m
- STC2200**: Maximum Load Capacity: 220t, Telescopic Boom: 6 Sections, 14.55-68m

■ ALL TERRAIN CRANE

- SAC1800**: Maximum Load Capacity: 180t, Telescopic Boom: 6 Sections, 13.5-62m
- SAC2200**: Maximum Load Capacity: 220t, Telescopic Boom: 6 Sections, 13.5-62m
- SAC2600**: Maximum Load Capacity: 260t, Telescopic Boom: 6 Sections, 15.65-73m
- SAC3000**: Maximum Load Capacity: 300t, Telescopic Boom: 7 Sections, 15.4-83m
- SAC3500**: Maximum Load Capacity: 350t, Telescopic Boom: 6 Sections, 15.2-70m
- SAC6000**: Maximum Load Capacity: 600t, Telescopic Boom: 7 Sections, 17.1-90m

■ ROUGH-TERRAIN CRANE

- SRC250**: Maximum Load Capacity: 25t, Telescopic Boom: 4 Sections, 9.9-31.5m
- SRC350**: Maximum Load Capacity: 35t, Telescopic Boom: 4 Sections, 10-31.5m
- SRC550**: Maximum Load Capacity: 55t, Telescopic Boom: 4 Sections, 11.25-34.5m
- SRC550H**: Maximum Load Capacity: 55t, Telescopic Boom: 5 Sections, 11.5-43m
- SRC750**: Maximum Load Capacity: 75t, Telescopic Boom: 5 Sections, 11.8-45m
- SRC1200**: Maximum Load Capacity: 120t, Telescopic Boom: 5 Sections, 13-49m





Quality Changes the World

## SANY AUTOMOBILE HOISTING MACHINERY

Address: SANY Industrial Park, Jinzhou Development Zone,  
Changsha, Hunan, China.  
Service Hotline: 4006098318  
Email: [crd@sany.com.cn](mailto:crd@sany.com.cn)  
For more information, please visit: [www.sanygroup.com](http://www.sanygroup.com)

For our consistent improvement in technology, specifications may change without notice.  
The machines illustrated may show optional equipment which can be supplied at additional cost.

Version: 2016.9

**Distributed By:**

--