

SPS 16000



**PALFINGER ASIA PACIFIC
STIFF BOOM CRANES**



SPS 16000

A (3 BOOMS)

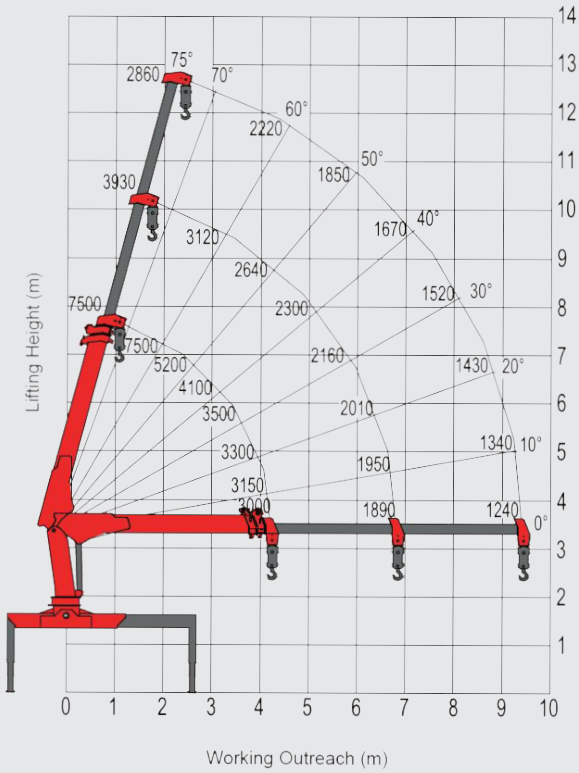

B (4 BOOMS)

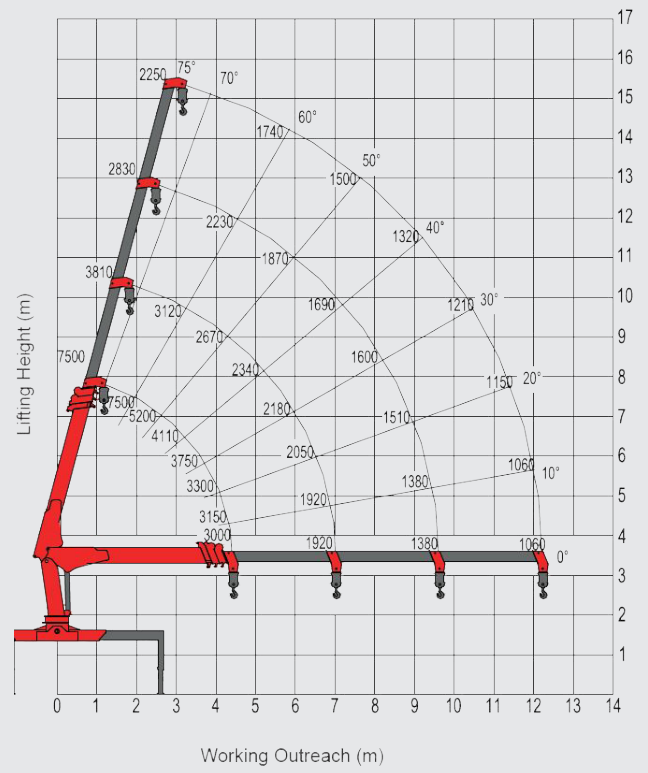

DIMENSIONS

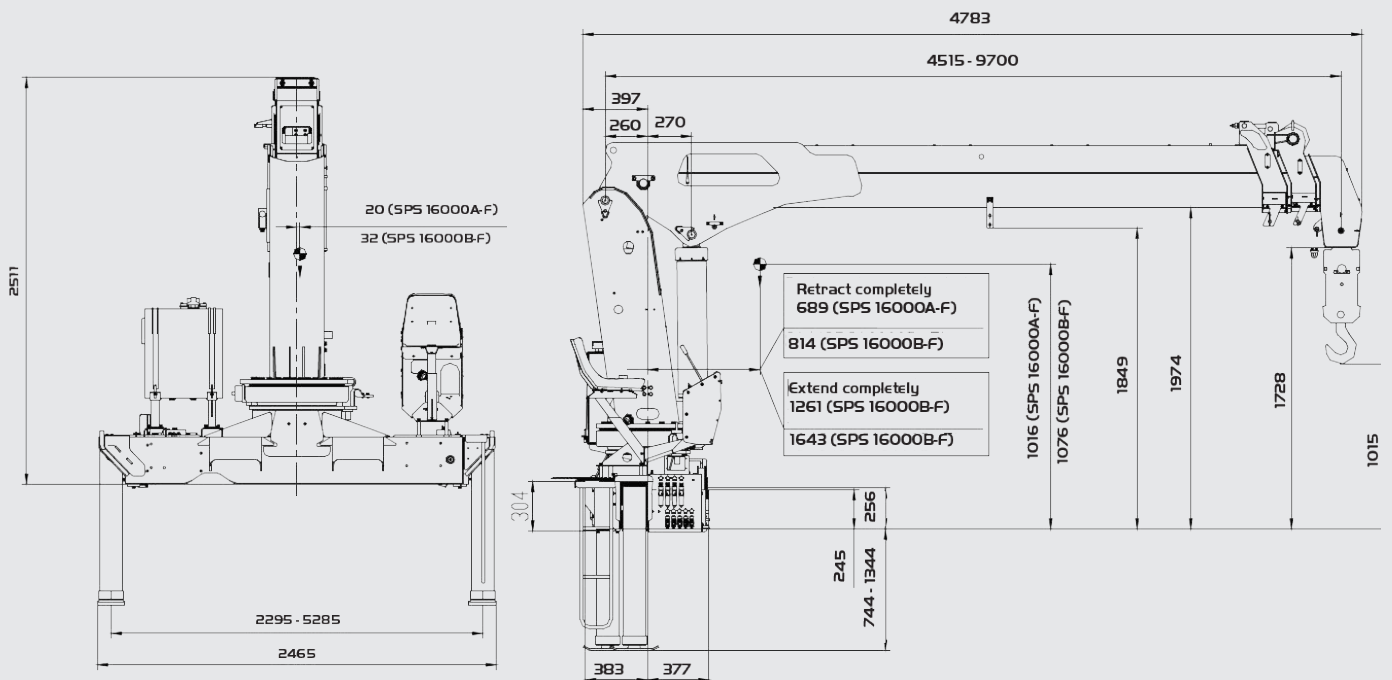

All dimensions are in mm

Diagrams may include optional configurations

LIFTING CAPACITY



SPS 16000 A			
Working radius	Boom length		
	4.5 m	7.1 m	9.7 m
2 m	7500	4590	
2.5 m	7000	3930	3670
3 m	5200	3460	3200
3.5 m	4100	3120	2860
4 m	3500	2850	2600
4.5 m		2640	2390
5 m		2460	2220
5.5 m		2300	2080
6 m		2160	1960
6.5 m		2010	1850
7 m			1760
7.5 m			1670
8 m			1590
8.5 m			1520
9 m			1430
9.5 m			1240
Recommended Rope lines	4	4	2

SPS 16000 B				
Working radius	Boom length			
	4.7 m	7.3 m	9.9 m	12.5 m
2 m	7500	5090		
2.5 m	7000	4340	4030	
3 m	5200	3810	3510	
3.5 m	4110	3420	3120	2970
4 m	3750	3120	2830	2670
4.5 m		2870	2590	2440
5 m		2670	2400	2250
5.5 m		2500	2230	2090
6 m		2340	2100	1960
6.5 m		2180	1980	1840
7 m		1920	1870	1740
7.5 m			1780	1650
8 m			1690	1570
8.5 m			1600	1500
9 m			1510	1440
9.5 m			1380	1380
10 m				1320
10.5 m				1270
11 m				1210
11.5 m				1150
12 m				1080
12.3 m				1060
Recommended Rope lines	4	4	2	2

- Longer boom variant for wider working areas and lifting height
- Strong lifting performance
- Proportional control valve for smooth contraility and high operating efficiency
- Higher transport capacity due to lighter crane structure
- Manufactured with European quality processes to ensure safety and reliability
- Suitable for installation on 2 axles trucks
- High Density (HD) Paint system provides better resale value retention and attractive aesthetics.

TECHNICAL SPECIFICATIONS

Model		SPS 16000 A-F	SPS 16000 B-F
Max. lifting moment	mt	16.0	16.0
Max. lifting capacity	kg/m	7000/2.5	7000/2.5
Number of booms	sections	4	5
Max. hydraulic outreach	m	9.5	12.3
Max. lifting angle	°	75	75
Slewing angle	°	Endless	Endless
Stabilizer spread (std.)	mm	5300	5300
Operating pressure	MPa	24/26	24/26
Recommended pump capacity	L/min	100	100
Oil tank capacity	L	100	100
Crane Weight	kg	2450	2650



LIFETIME EXCELLENCE

PALFINGER LOADER CRANES ARE CONVINCING DUE TO THEIR **SUPERIOR LIFE-CYCLE PERFORMANCE**. THEY ARE THE MOST ECONOMICAL AND ALSO THE MOST RELIABLE OVER THE ENTIRE PRODUCT LIFE. FROM SOLUTION FINDING TO RE-SALE.

BETTER
SOLUTIONS

BETTER
EFFICIENCY

BETTER
ERGONOMICS

HIGHER VALUE
RETENTION

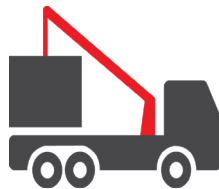

HIGHER
AVAILABILITY

HIGHER
SERVICEABILITY

BETTER
ECOLOGY

MORE
RELIABILITY

For further information please visit: www.palfinger.com/thebrand

PALFINGER ASIA PACIFIC PTE LTD

3 INTERNATIONAL BUSINESS PARK | NORDIC EUROPEAN CENTRE
05-25/26 | 609927 | SINGAPORE
T +65 6591 9191 | F +65 6591 7737
Enquiries: asia@palfinger.com
Website: www.palfinger.com

